

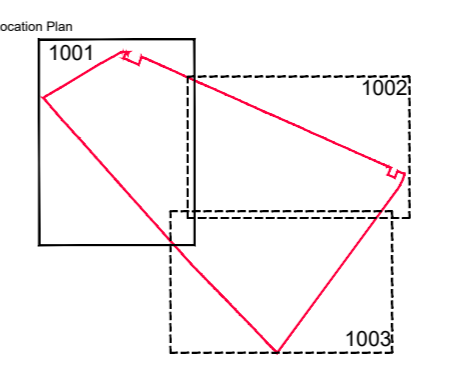

Refer to drawing D3438-FAB-00-XX-DR-L-1002



**fabrik** Lenden House | 16 Lenden Street | Abingdon | Hampshire | GU24 1HD  
 T: 01429 992650 | E: [fabrik@fabrik.com](mailto:fabrik@fabrik.com) | W: [www.fabrik.com](http://www.fabrik.com)

Project: **Enterprise Park** Client: **Lovell**

Drawing Title: **Landscape General Arrangement Plans Sheet 1 of 3**

Prepared by: **dg** Checked by: **sg** Drawn Scale: **1:200 @ A1** Date of First Issue: **mar | 2025**

ISSUED FOR PLANNING APPROVAL

Drawing Number: **D3438-FAB-00-XX-DR-L1001** Revision: **PL02**

Revision	Date	Phase	Drawn	Checked
PL02	16.02.2026	Issued for Planning - RPZ Amendments	sg	ah
PL01	12.03.2025	Issued for Planning	sg	ah
PL01	05.03.2025	DRAFT - Issued for Planning	sg	ah
Revision	Date	Phase	Drawn	Checked

Disclaimer:  
 1. This drawing is copyright of fabrik ltd. It must not be copied or reproduced without written consent from the owner.  
 2. Do not scale from this drawing. Only figured dimensions are to be taken from this drawing.  
 3. All contractors must visit site and be responsible for taking and checking all dimensions related to the works shown on the drawing prior to fabrication or setting out.  
 4. This drawing uses coloured lines. Please do not rely on a monochrome copy.

External References: